

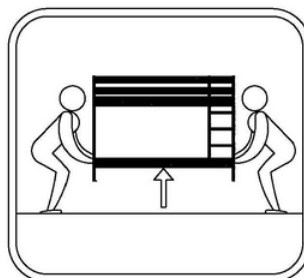

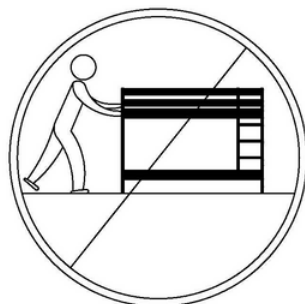

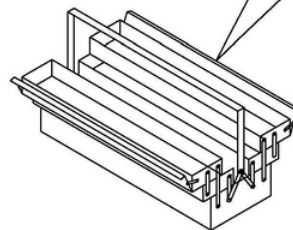

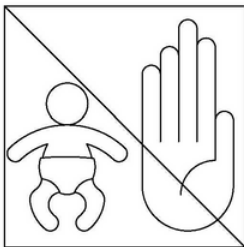

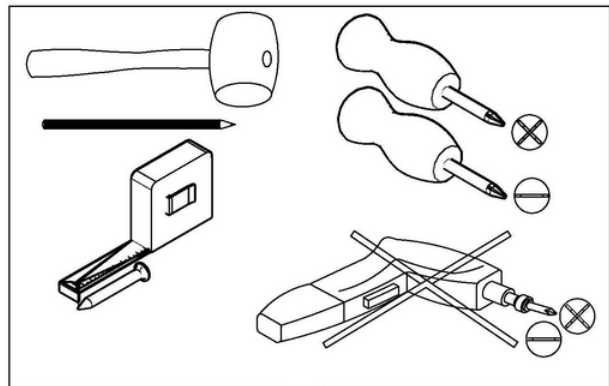
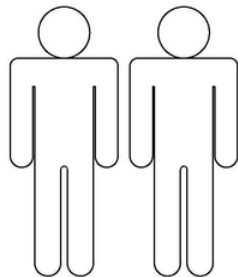
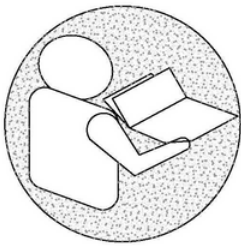
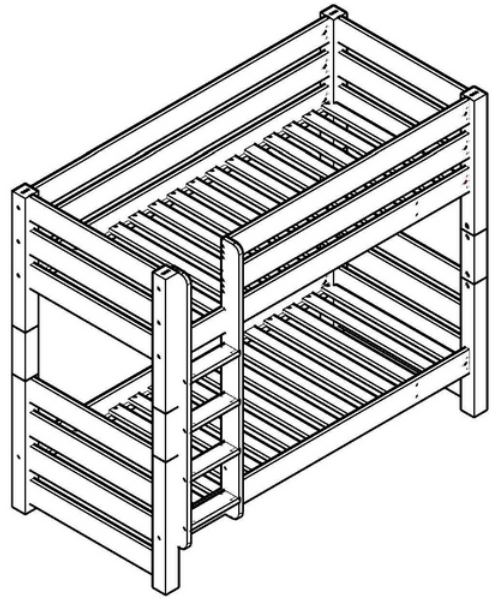
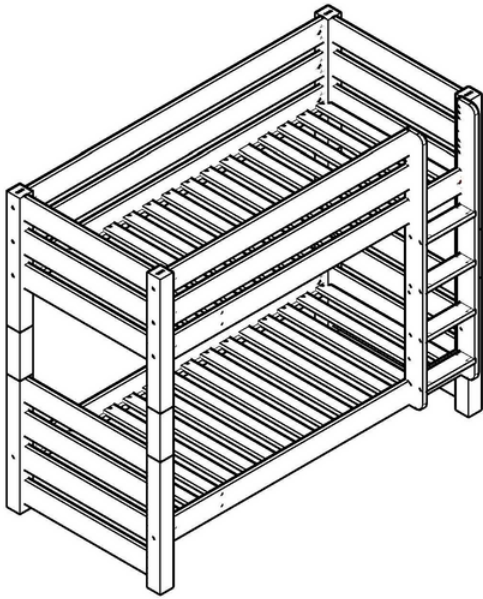
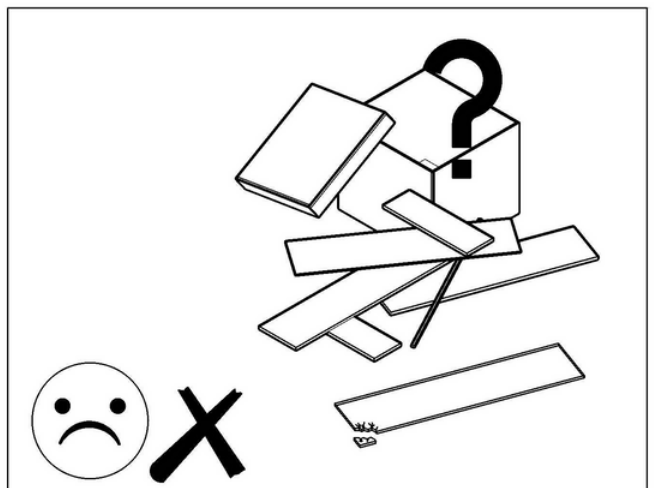
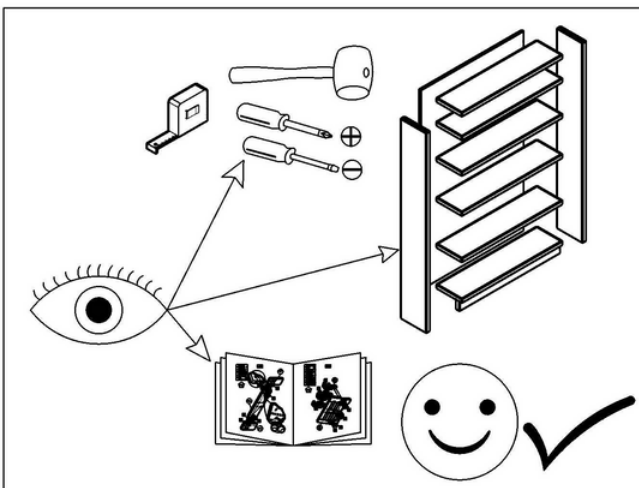
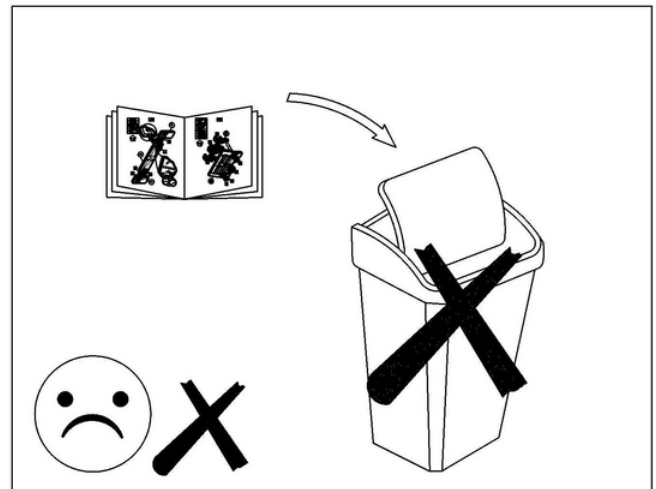
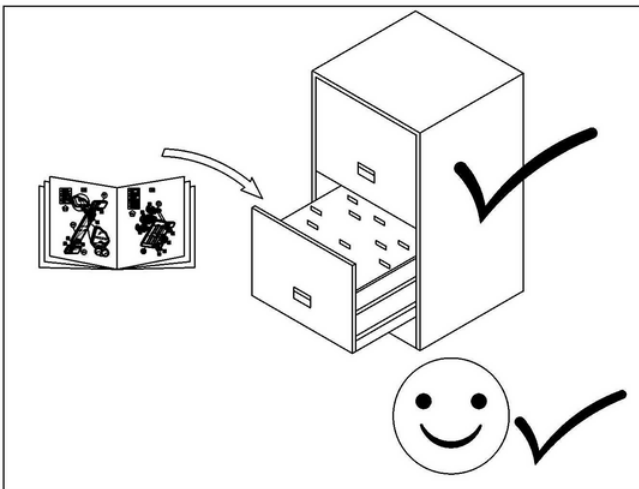
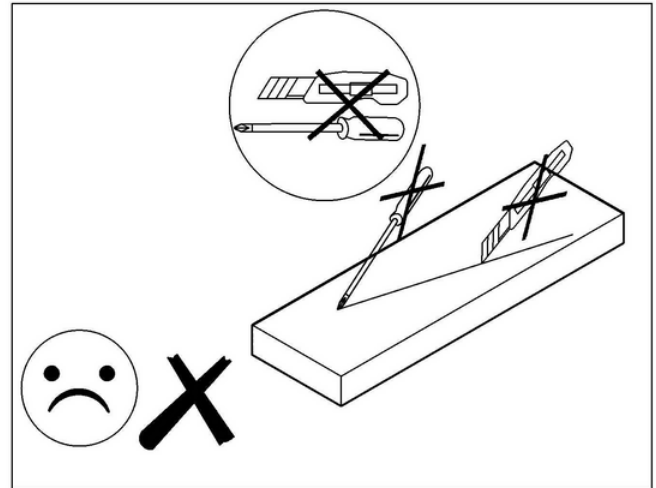
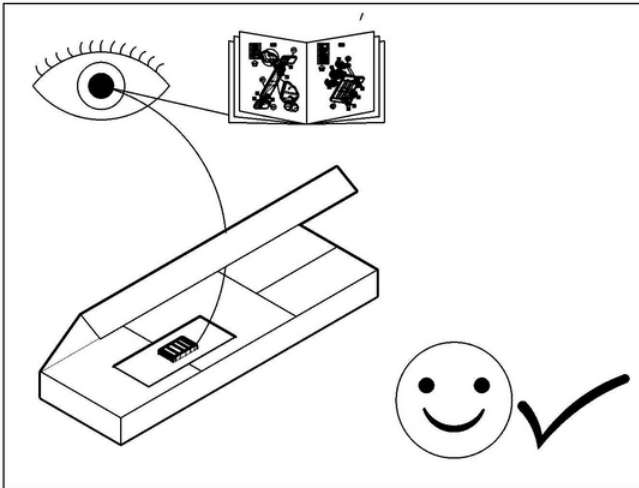
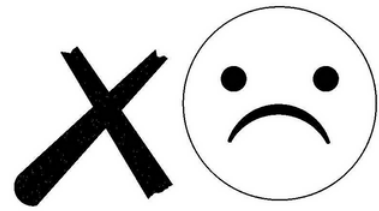
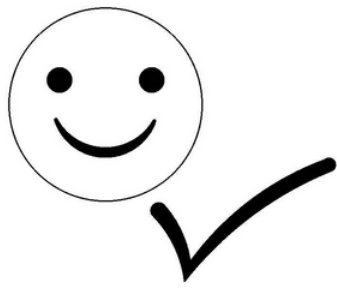
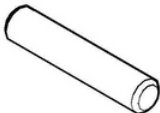

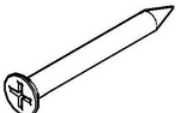
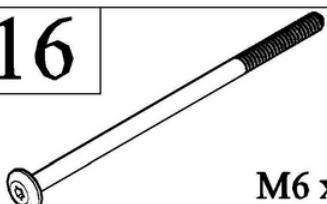
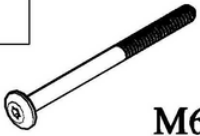
ATLAS | ALPY



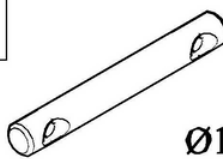
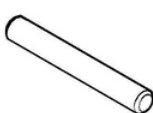

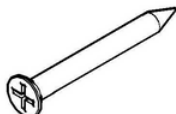
K4	x 28  Ø10 x 40	H4	x 14  Ø10X 13
S8	x 6  Ø4 X 60	J16	x 14  M6 x 120
J13	x 2  M6 X 93	H7	x 2  M6/Ø8 x 15
M3	x 16  Ø16 X 19	M5	x16  M10 x 13
F2	x 1  HEX 4 mm	H5	x8  Ø10 x 80
K9	x8  Ø8 x 60	C3	x20  Ø7 x 50
S5	x64  Ø3,5 x 30	X1	x2  63,5x25x25
B2	x2  75 x 25 x 15	S3	x2  Ø3,5 x 16
		V1	x2  V1-1 V1-2 Ø8x40/Ø4x50

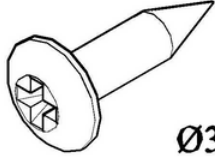
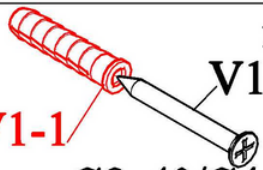
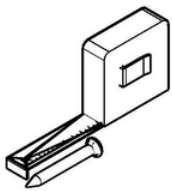

ca 35 mm

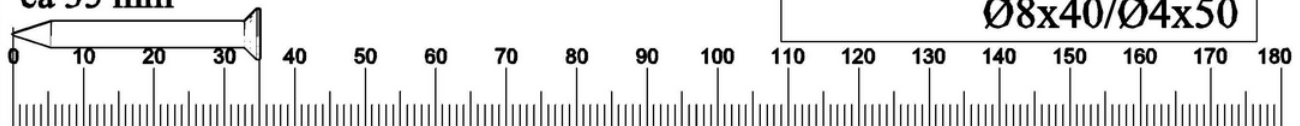

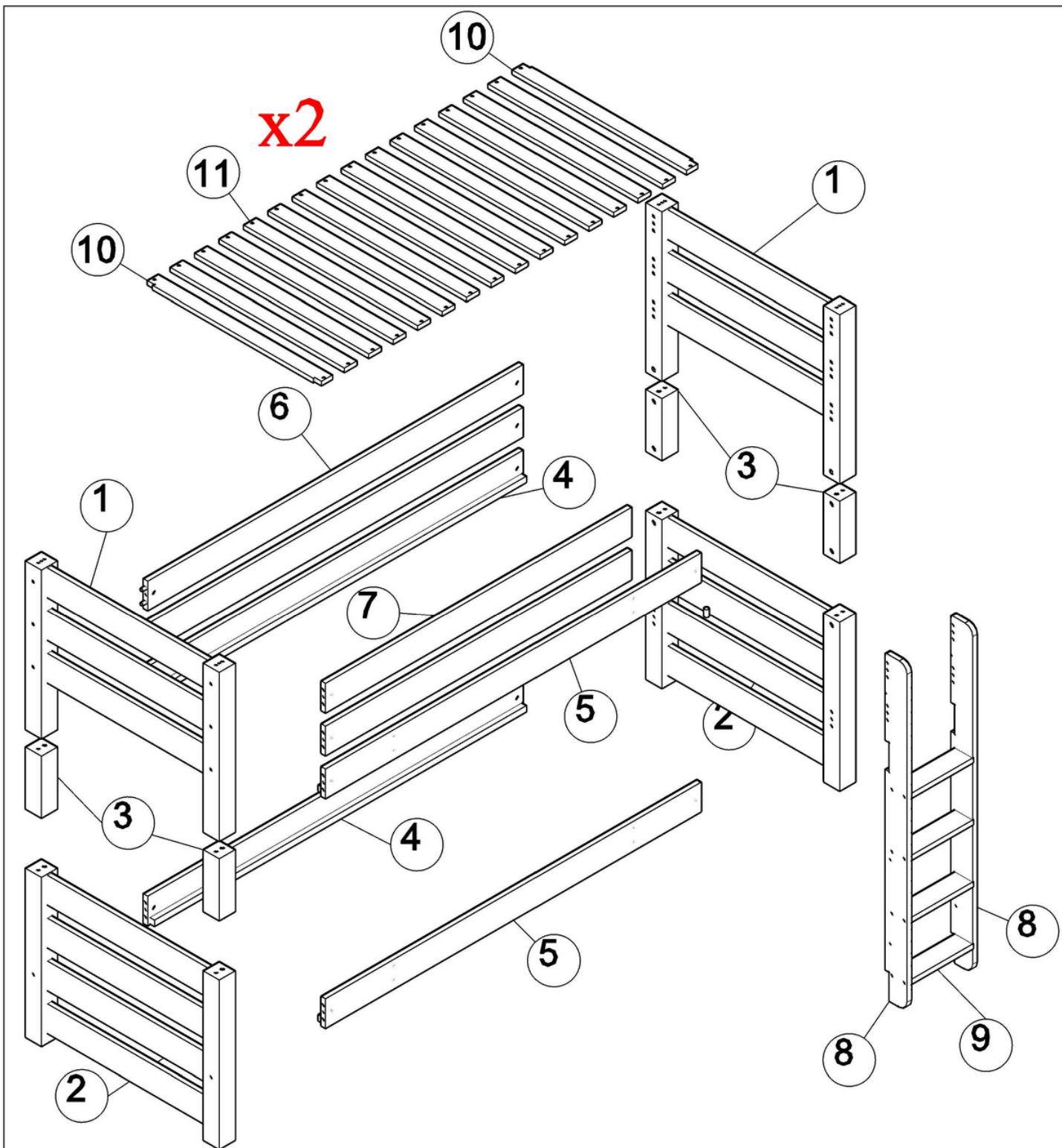

TEILE NR	ANZAHL	MASS L X B X T(MM)	✓	TEILE NR	ILOŚĆ	WYMIAR L X B X T(MM)	✓
1	2	998 X 695 X 78/20		6	2	1942 X 130 X 20	
2	2	998 X 695 X 78/20		7	2	1542 X 130 X 20	
3	4	335 X 78 X 78		8	2	1549 X 110 X 20	
4	2	1942 X 130 X 20		9	4	320 X 90 X 25	
5	2	1942 X 130 X 20		10	4	898 X 63 X 17	
				11	28	898 X 63 X 17	

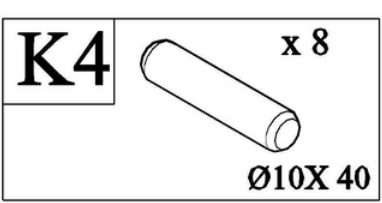
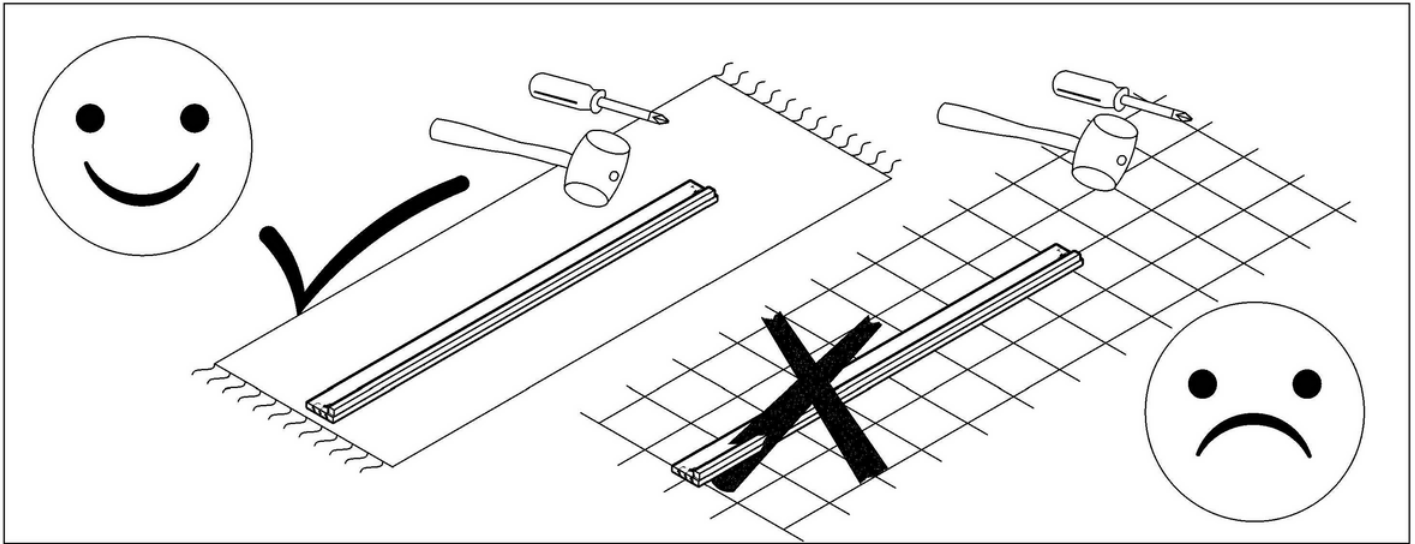

1

4 x2

2

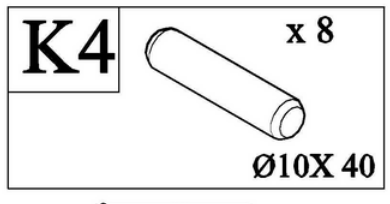
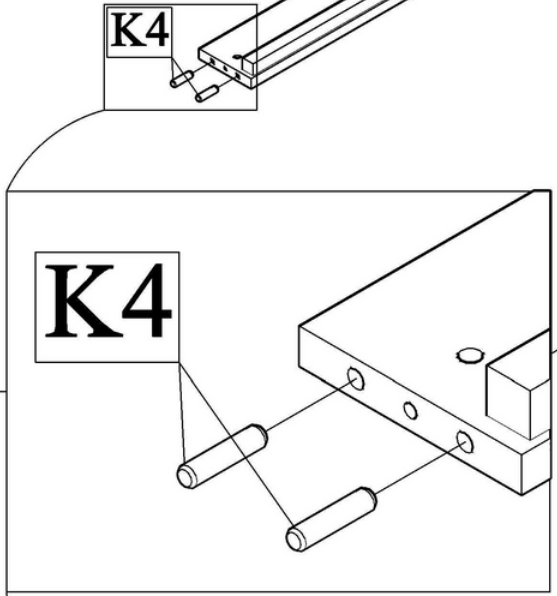

5 x2

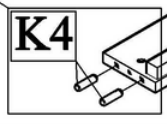

K4 x 8
Ø10X 40

3

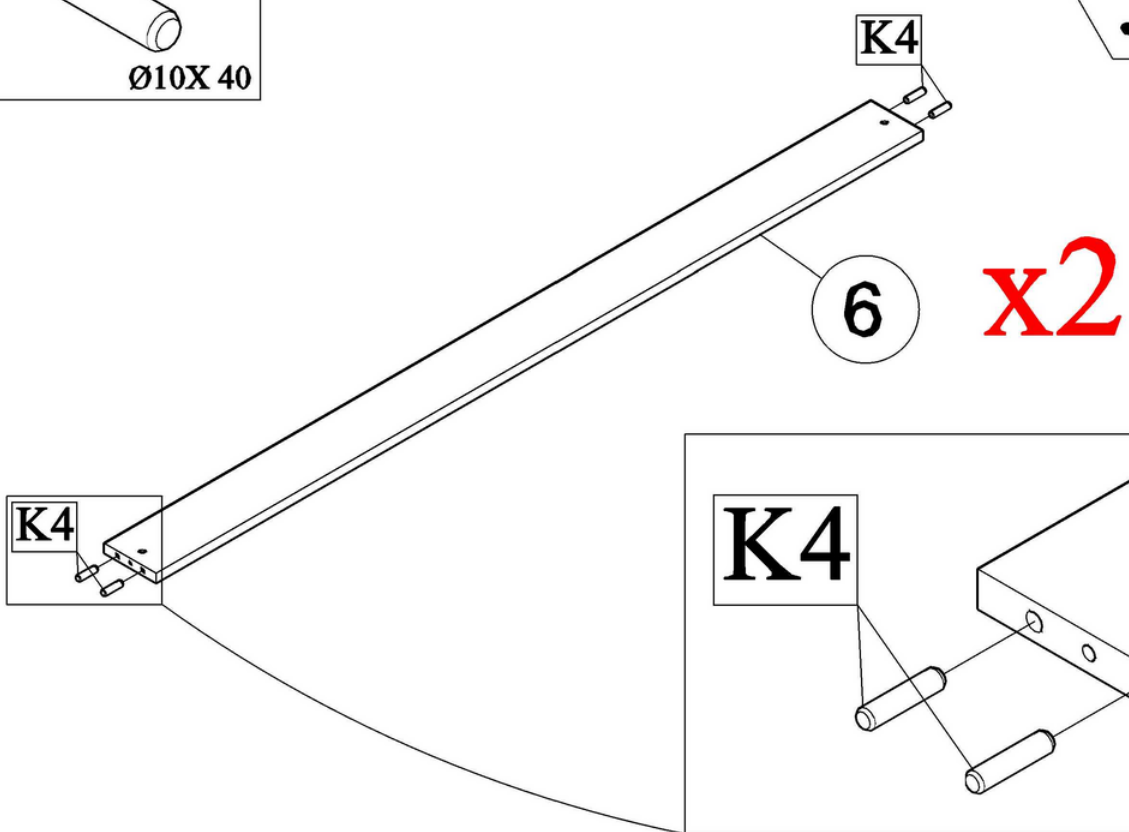

K4 x 4
Ø10X 40

4

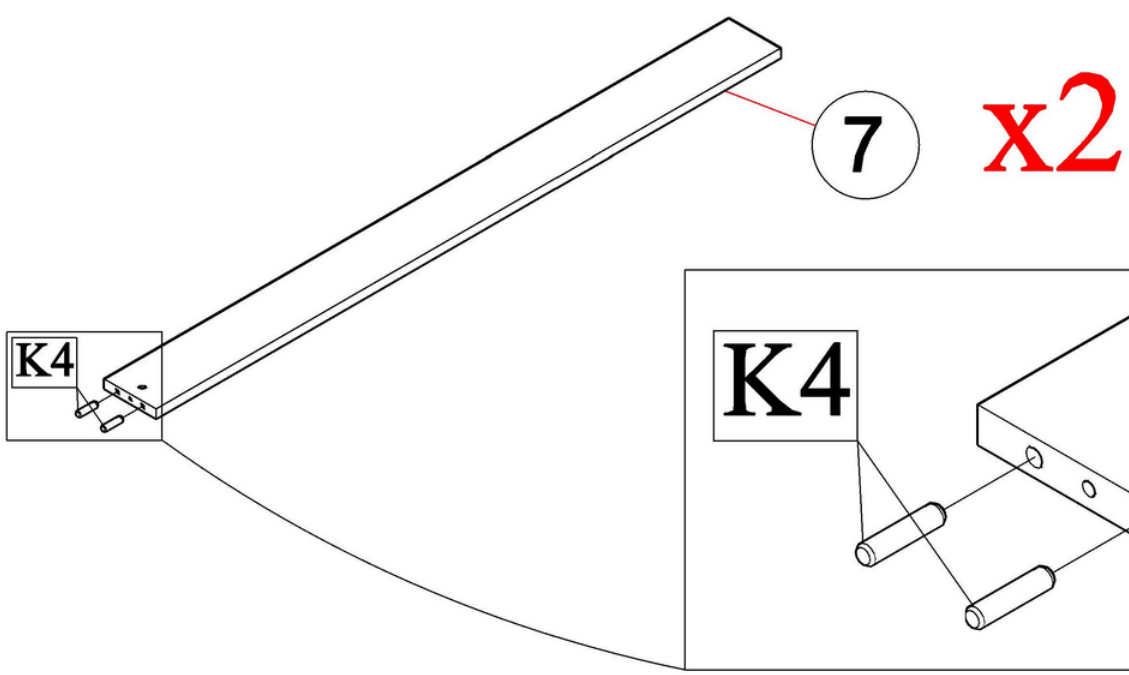

M3



x 4

Ø16x 19

5

1

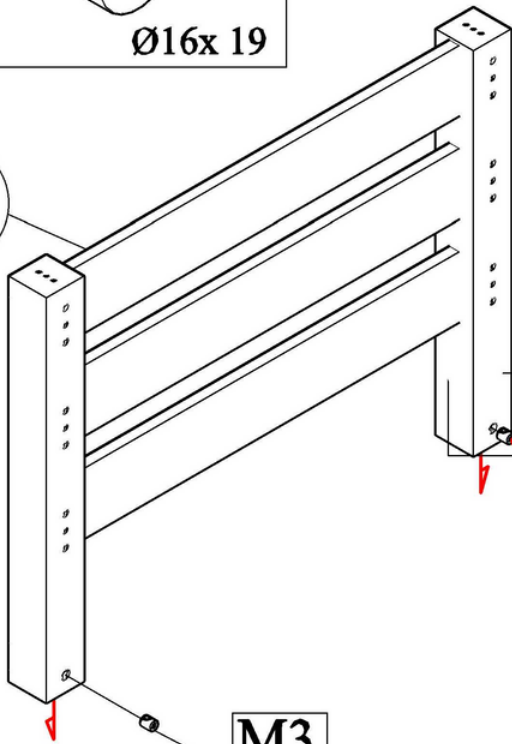

x2

M3

M3

M3

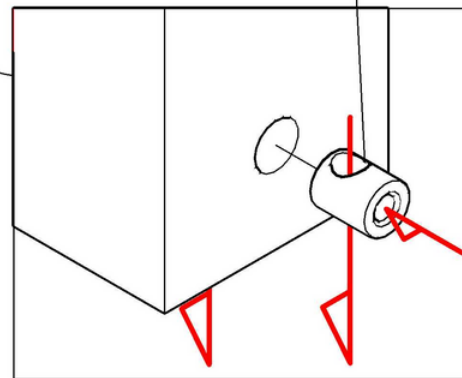

M3



x 4

Ø16x 19

6

2

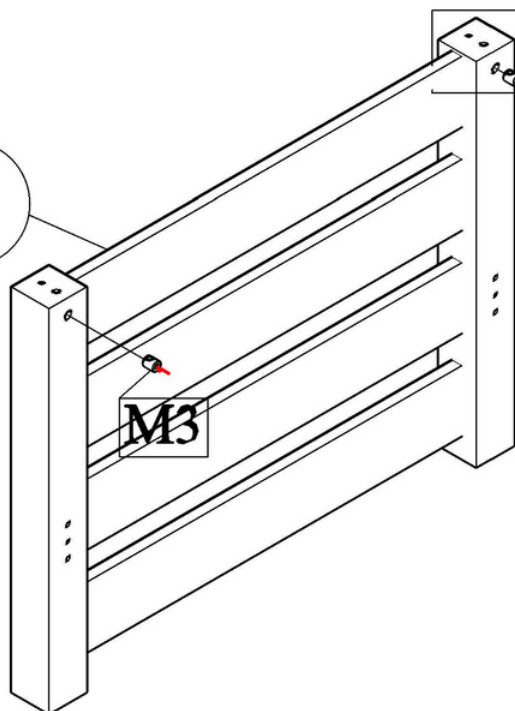

x2

M3

M3

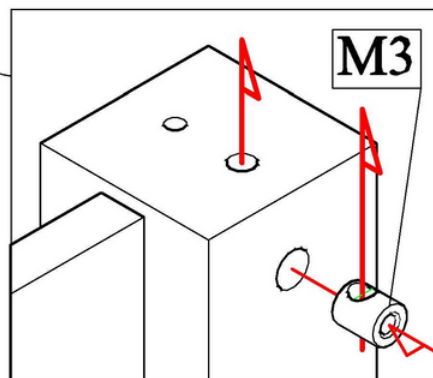

M3

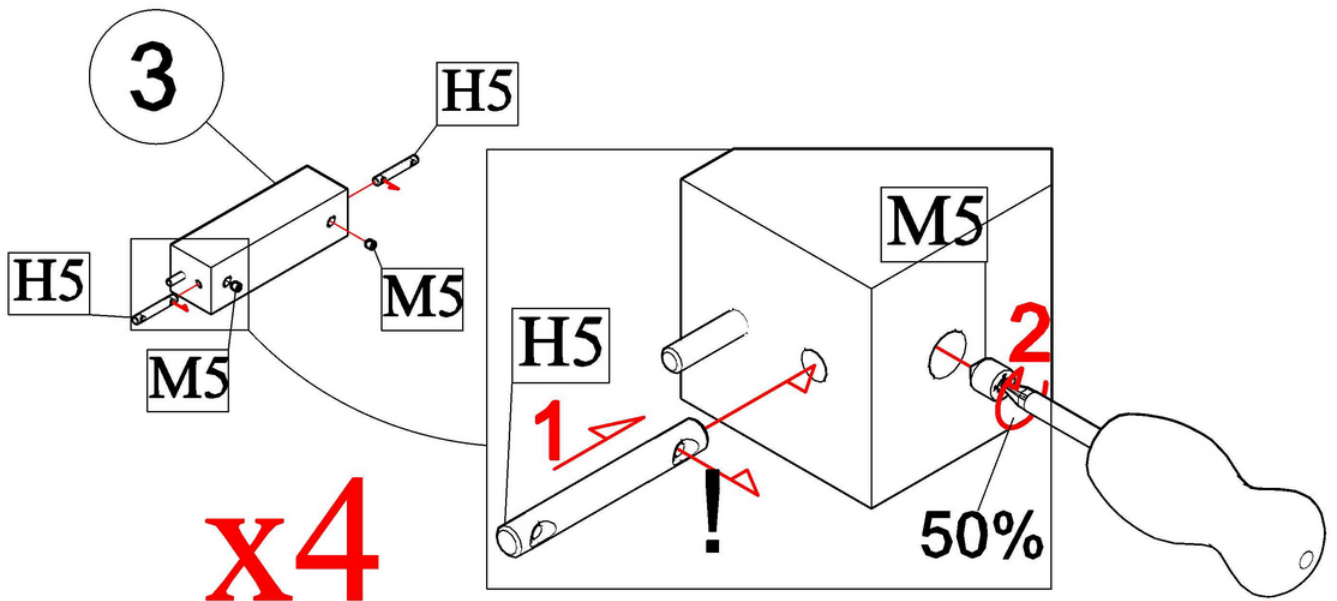
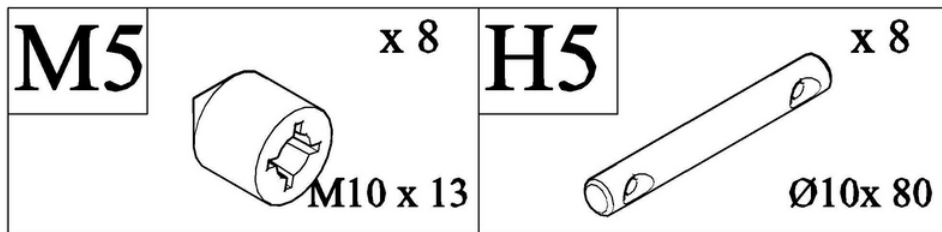
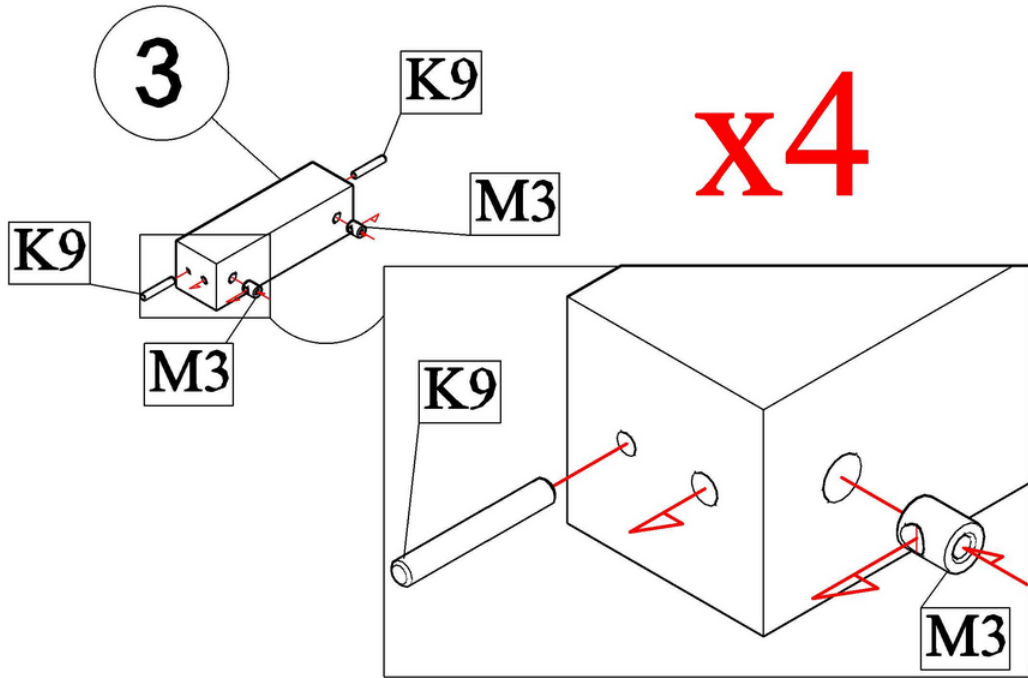
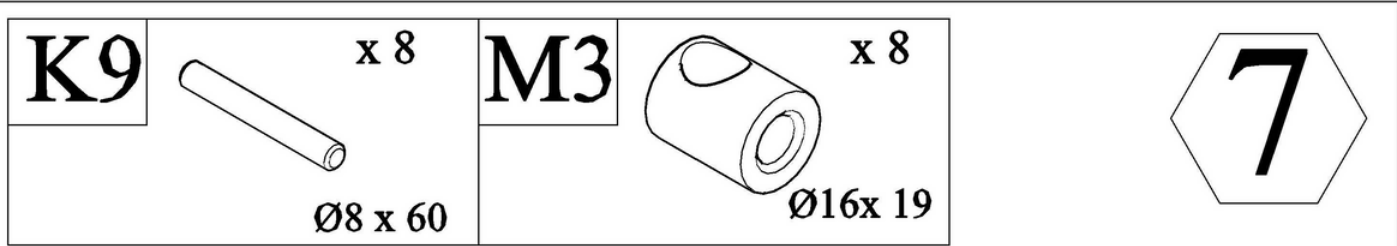

M5

x 4



M10 x 13

3



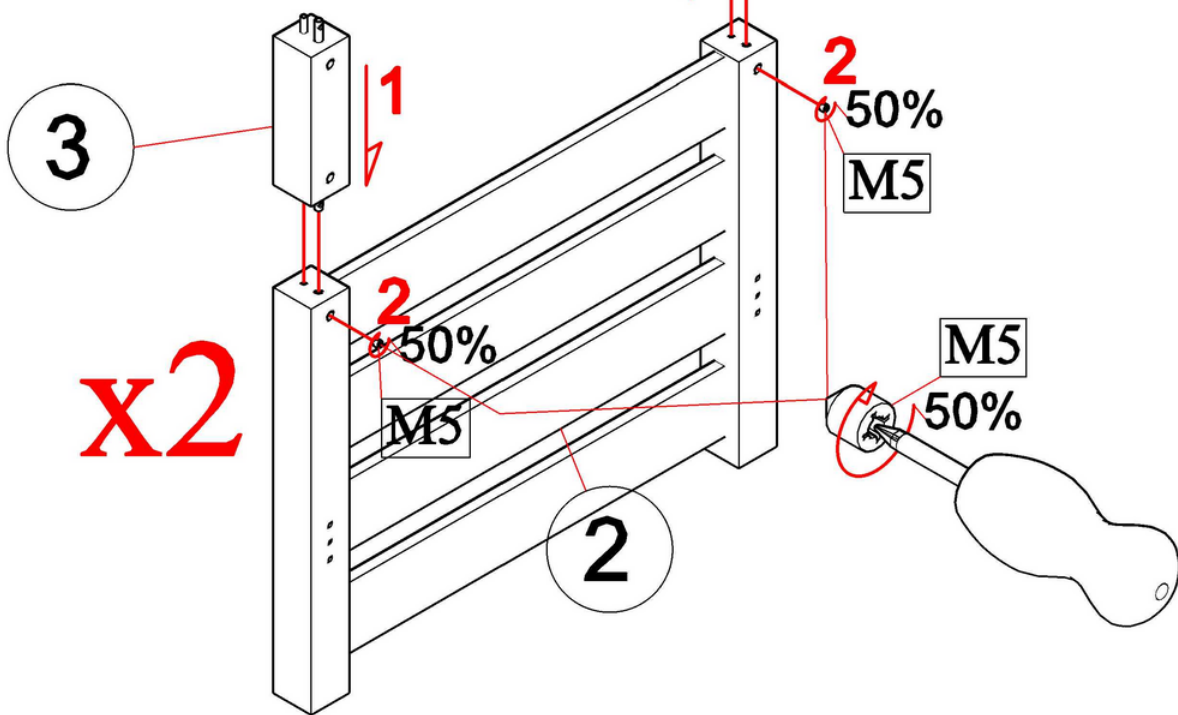

9

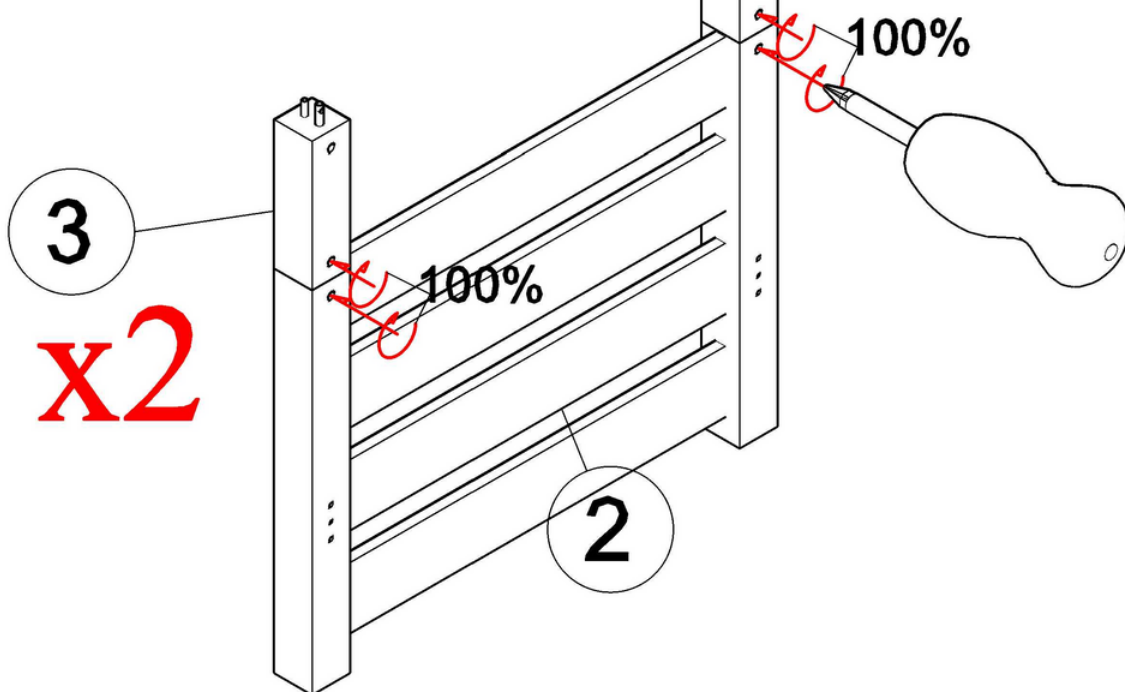

3

10



H4		x 4	F2		x1
J16		x 4	J13		x 2
		M6 x 120			M6 x 93
					Ø10x 13
					HEX 4mm

11

J16

H4





5

H4

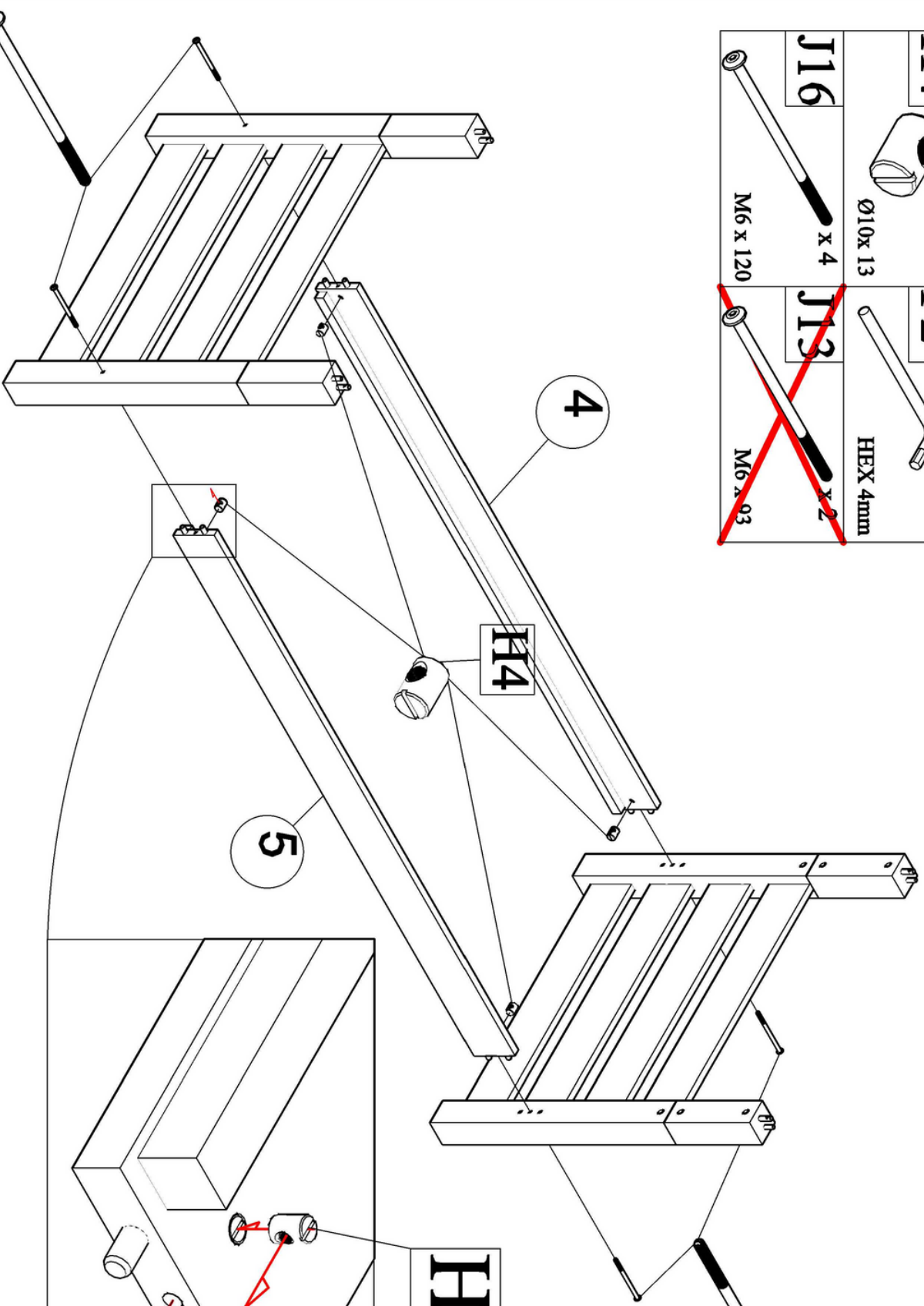
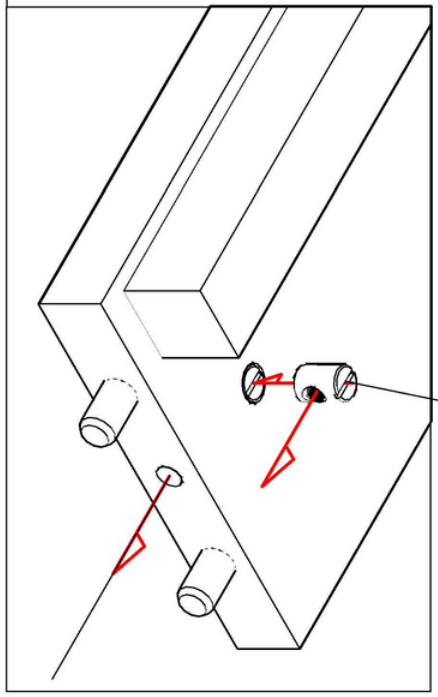
4

J16



H4		x 8	F2		x1
J16		x 8	J13		x 2
	M6 x 120			M6 x 93	

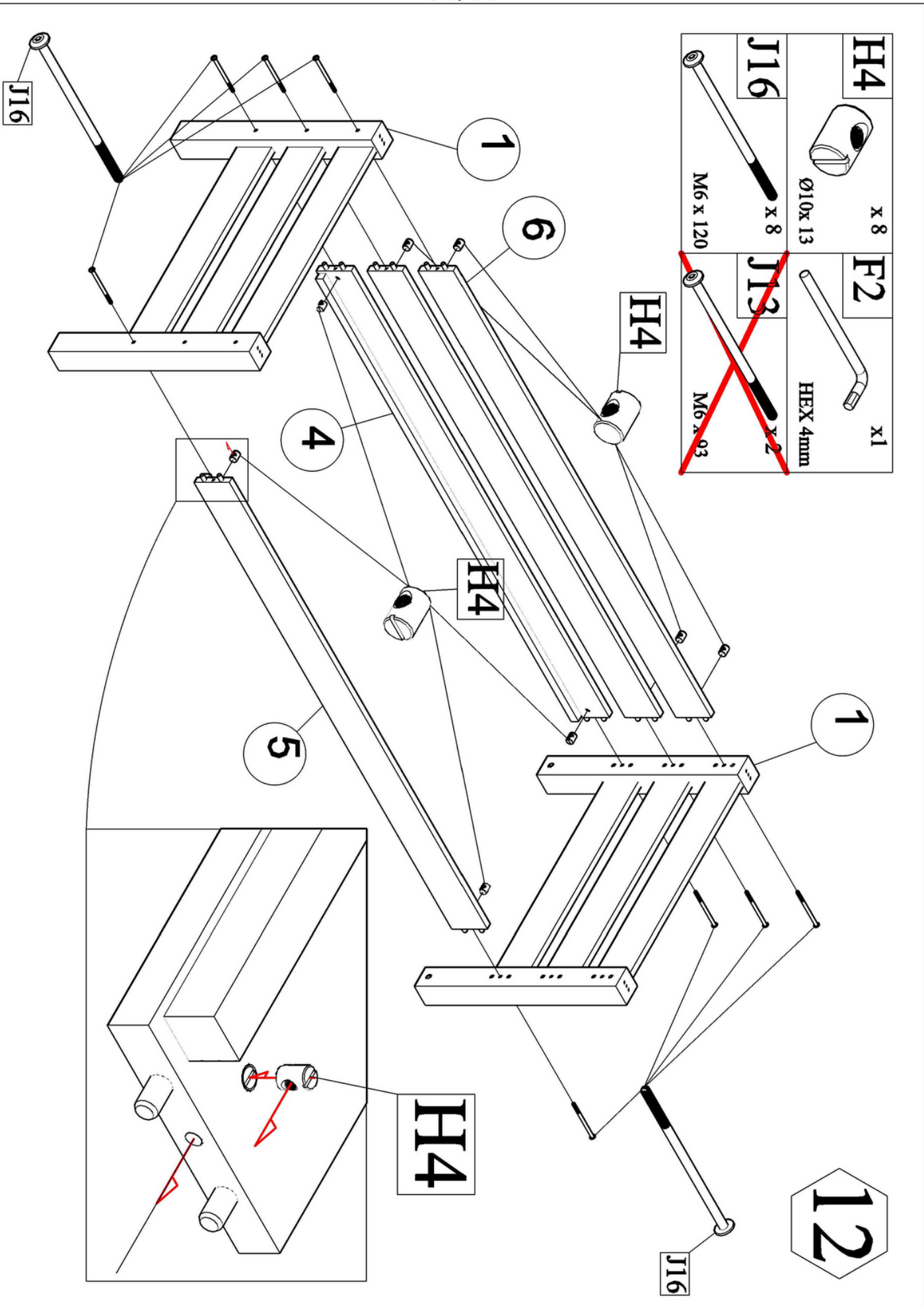

12

J16

H4

H4

H4

H4

J13

J16

H4

F2

x1

x 8

Ø10x 13

HEX 4mm

x 8

M6 x 120

M6 x 93

1

6

4

5

1

J16

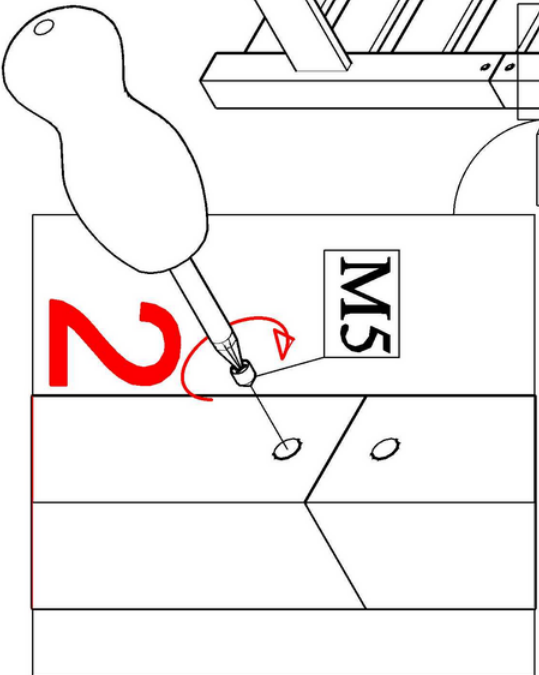
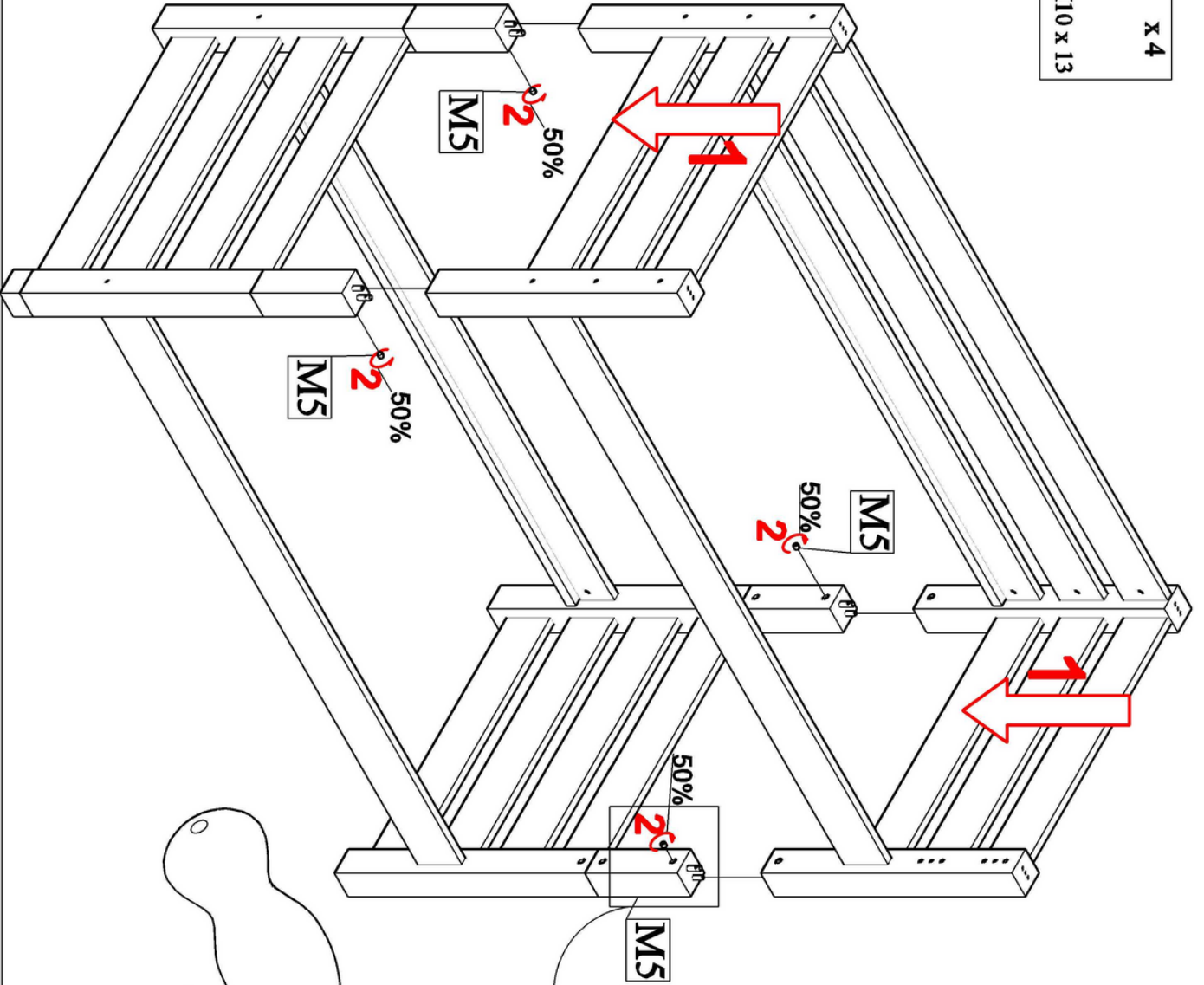
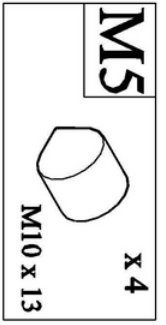

13

13/24

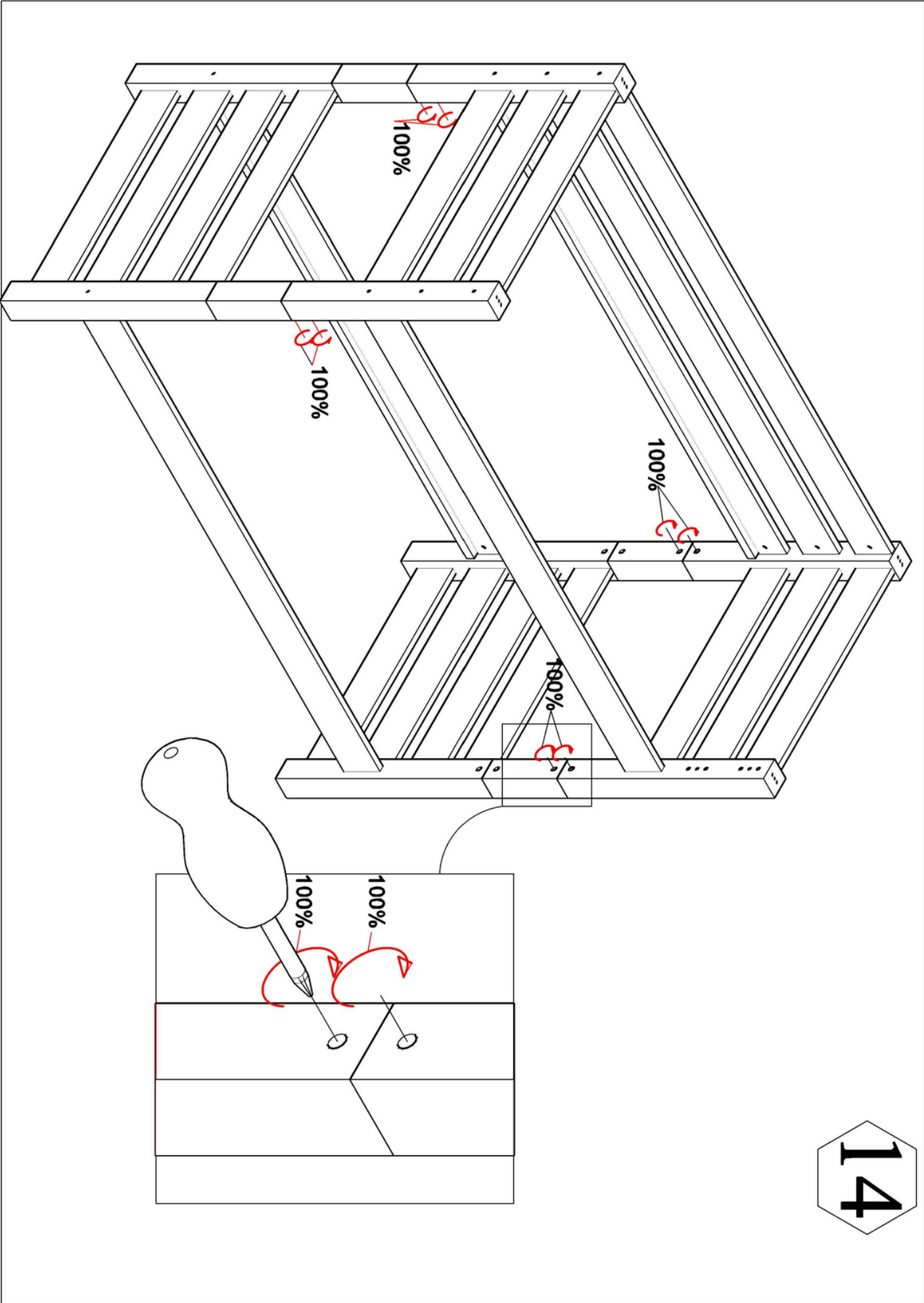

F2

x1

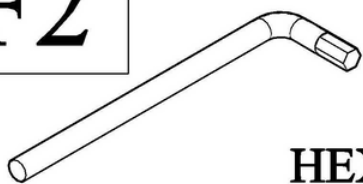

HEX 4mm

C3

x16

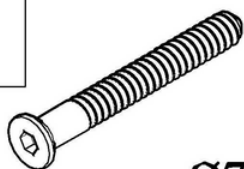

Ø7 x 50

15

C3

C3

8

9

8

R

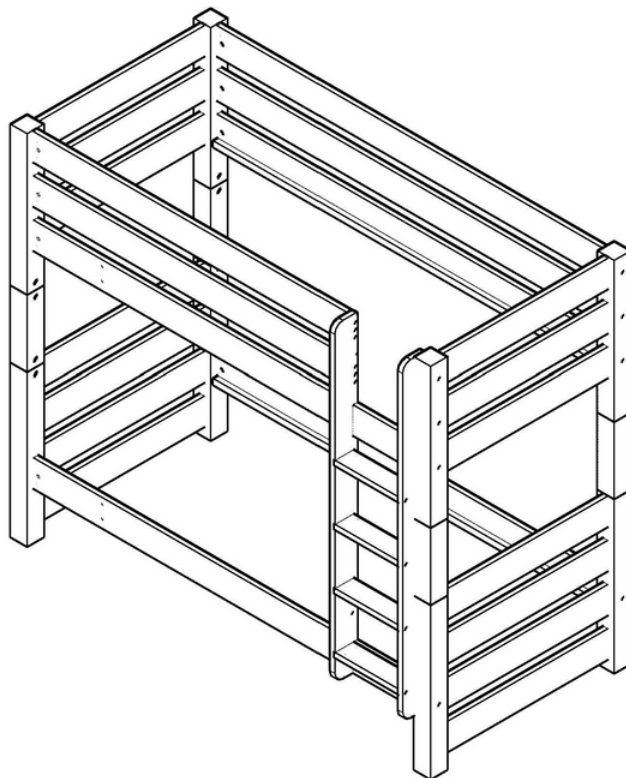

F2

x1

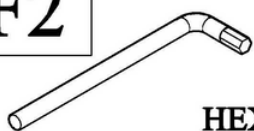

HEX 4mm

C3

x4

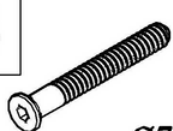

Ø7 x 50

16 R

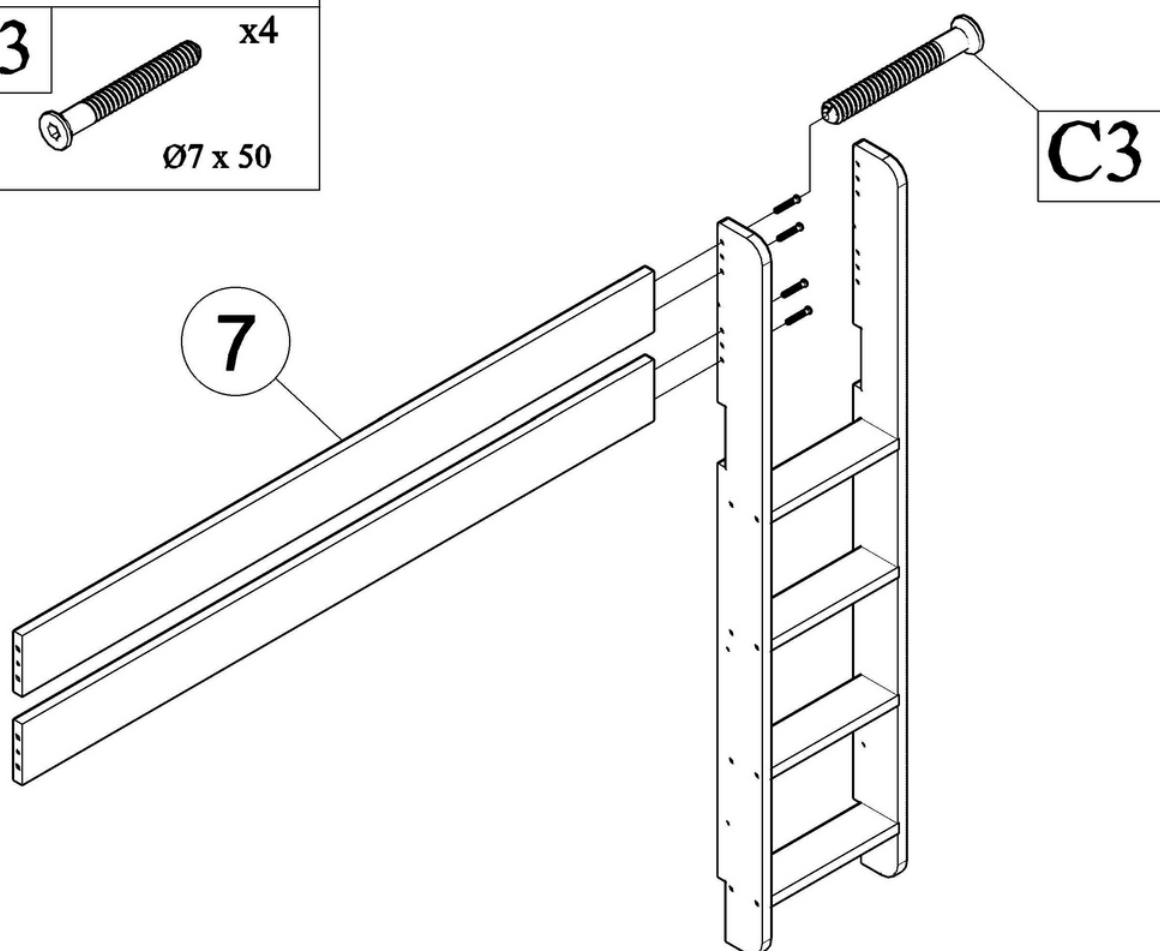

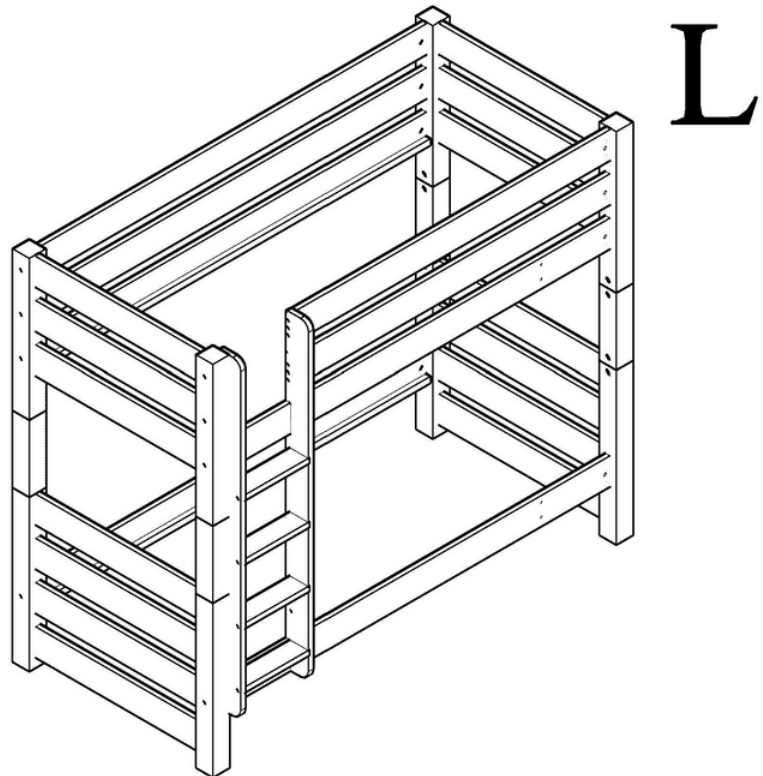

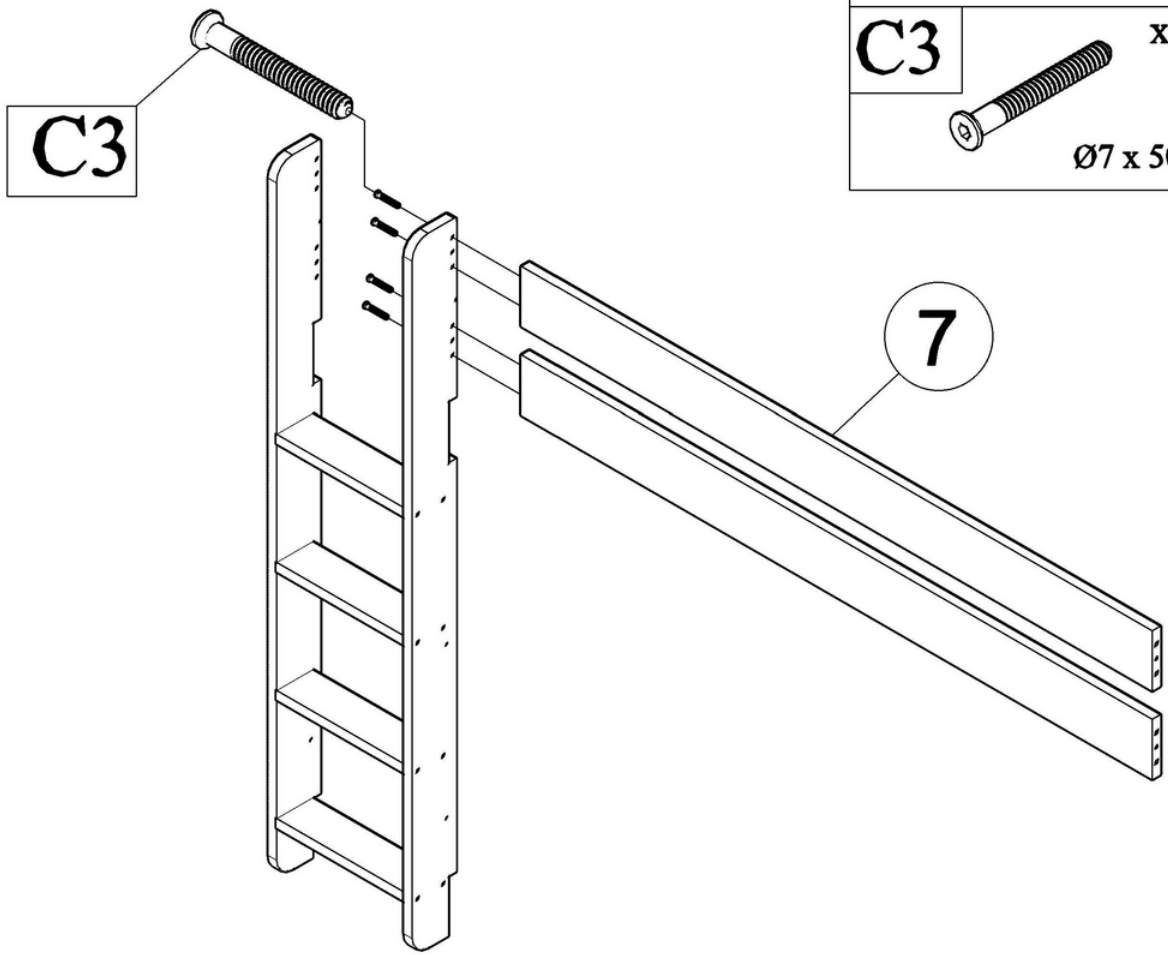

16 L

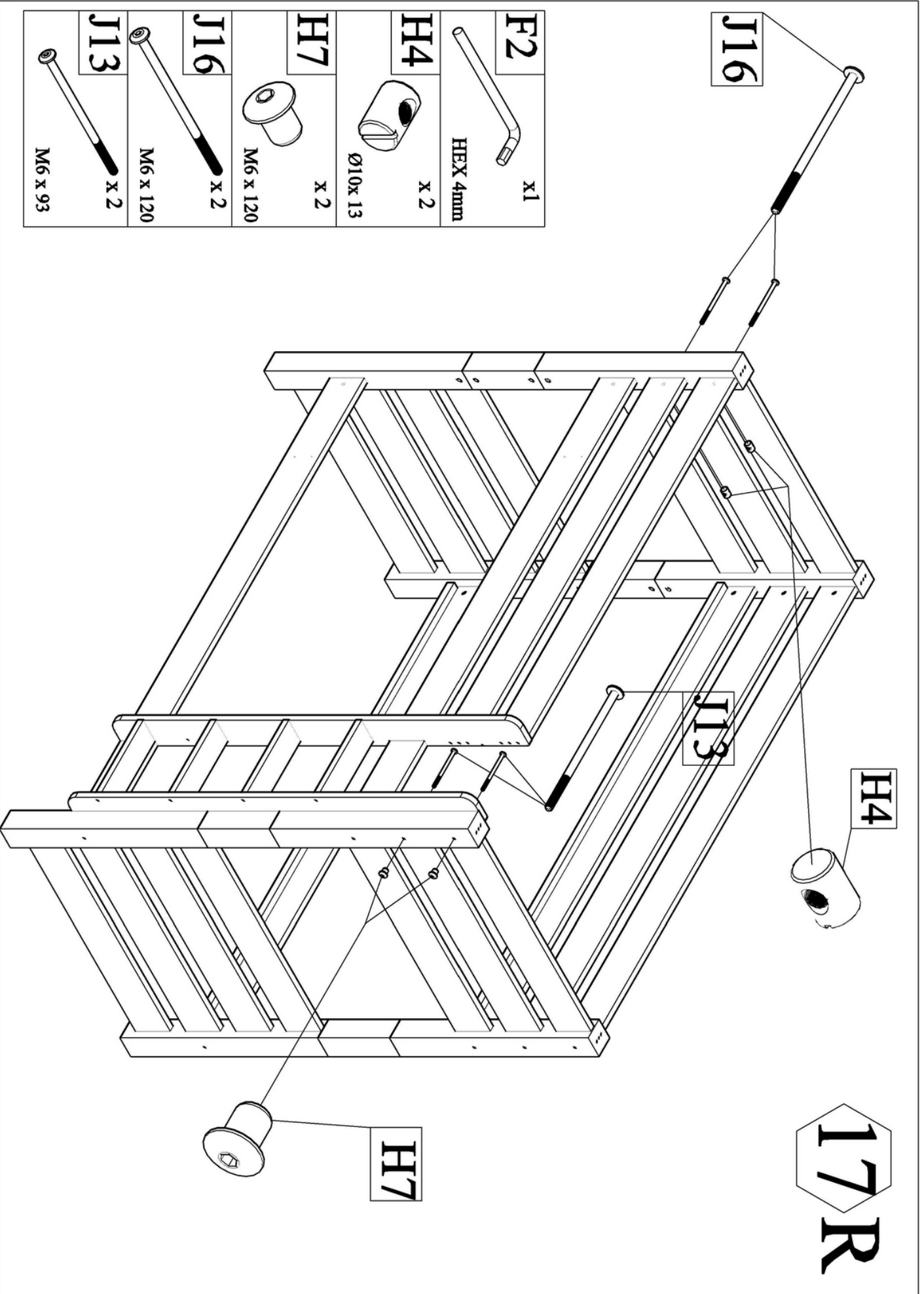

17 R

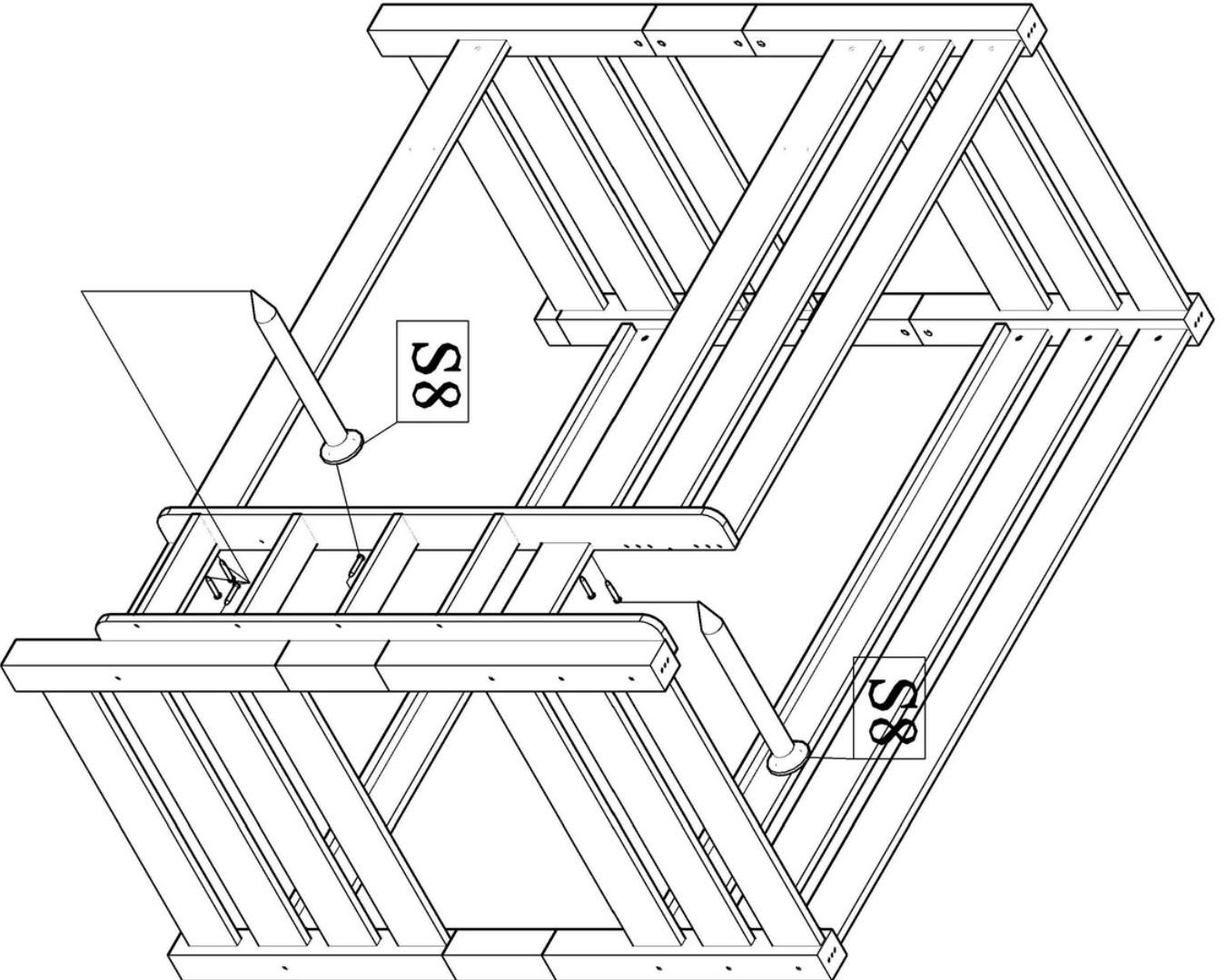

S8 x 6
Ø4 X 60



18R

17L

19/24

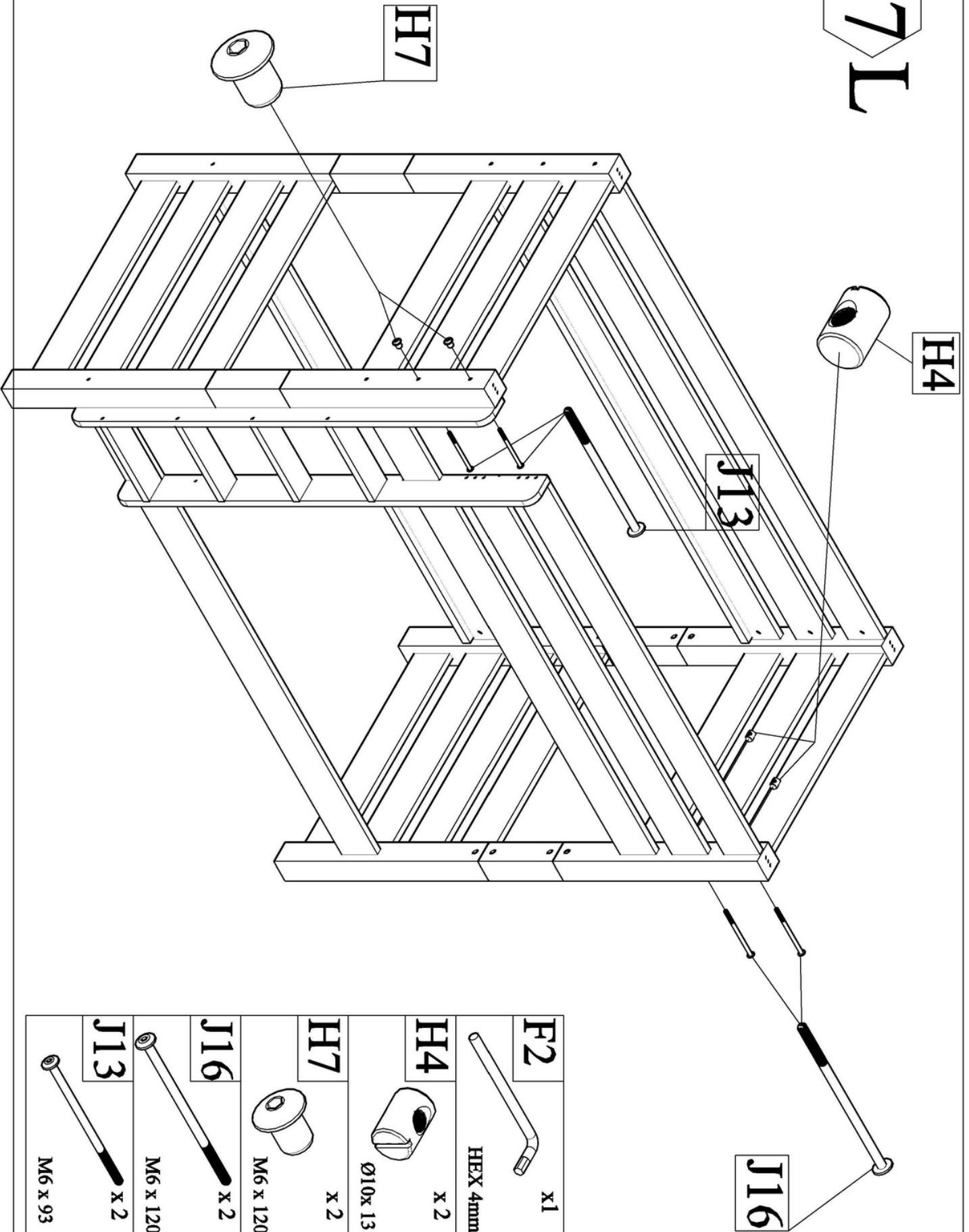

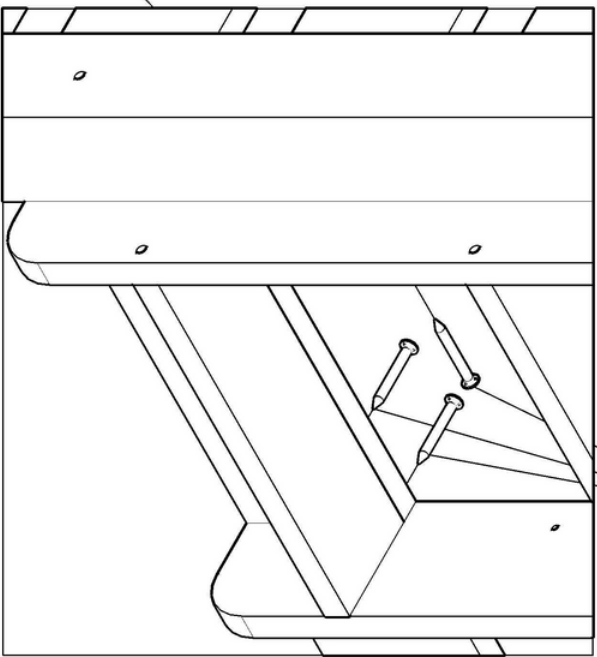
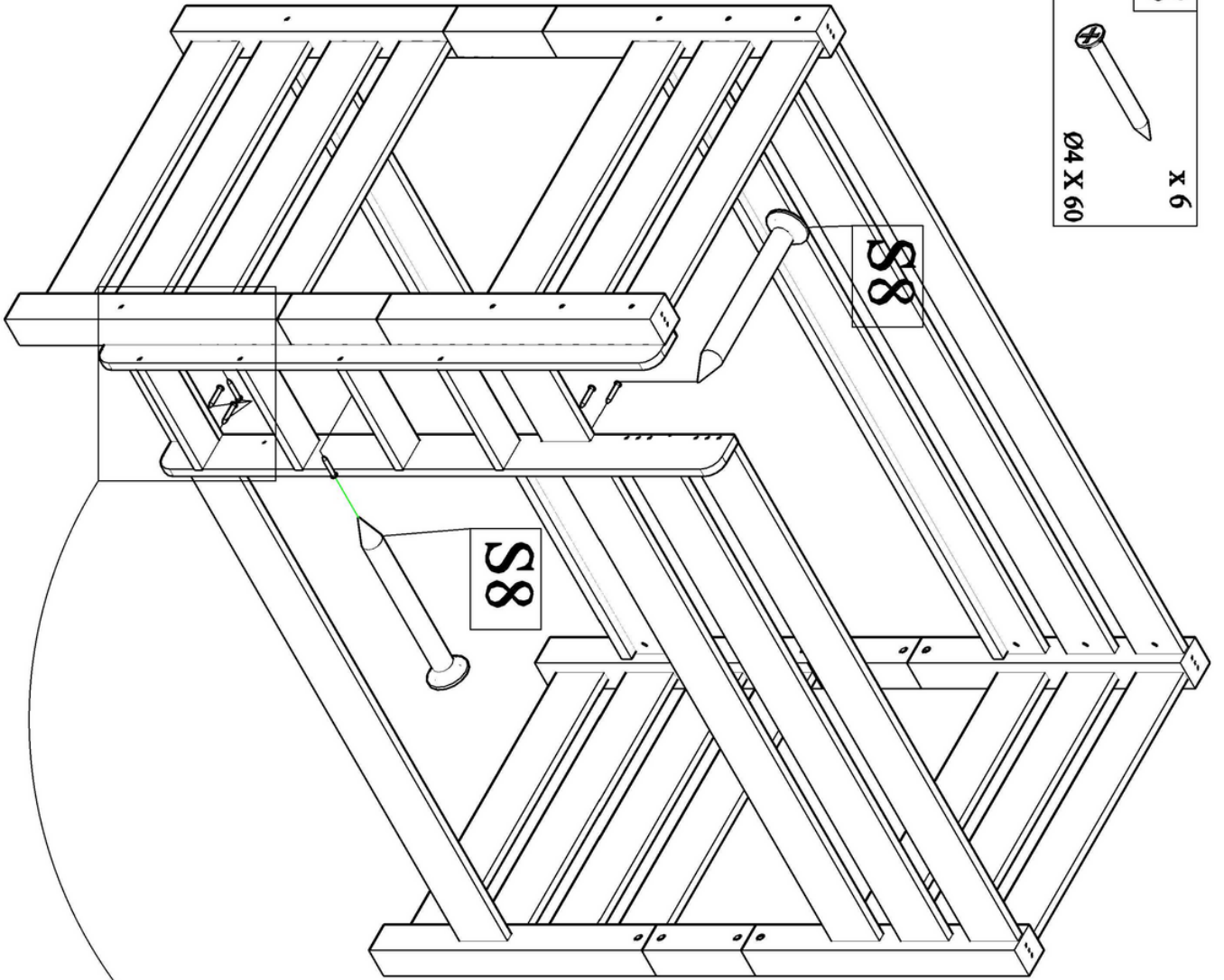

S8

x 6
Ø4 X 60



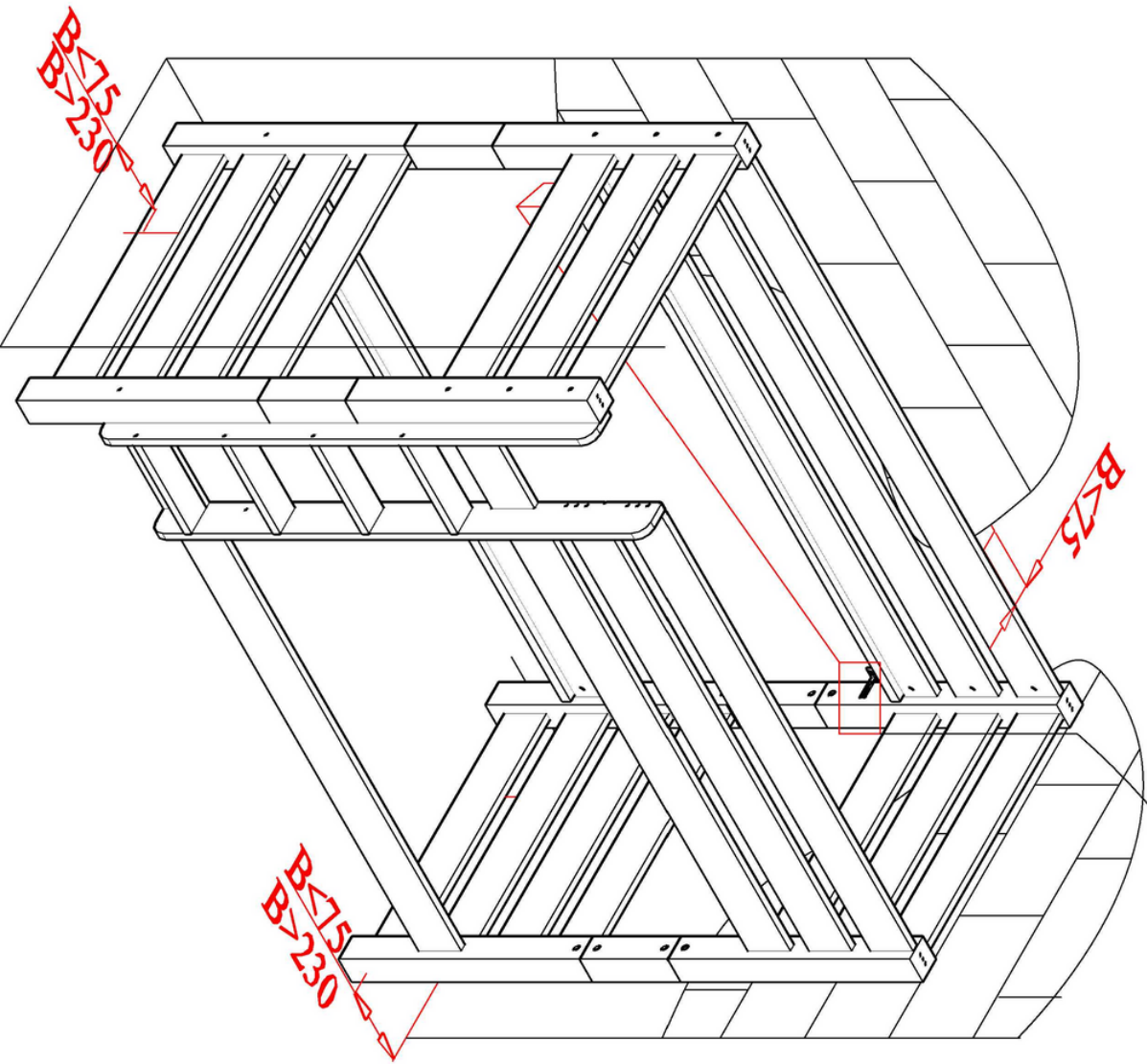

18L

S8

B2  75 x 25 x 15 x 2	V1  Ø8x40/Ø4x50 x 2 V1-1 V1-2	S3  Ø3,5 x 16 x 2
---	--	---

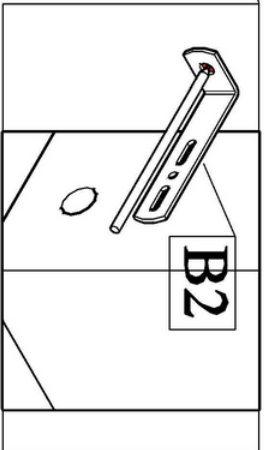
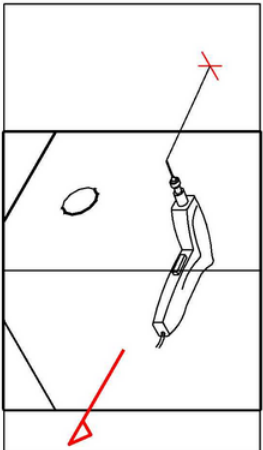
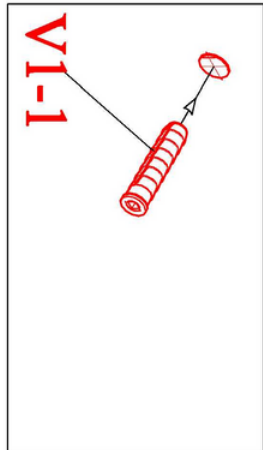
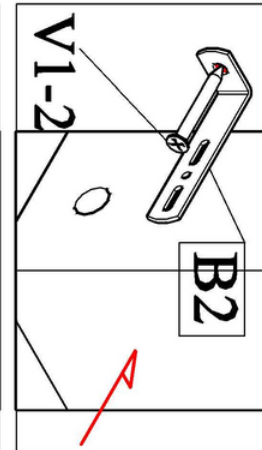
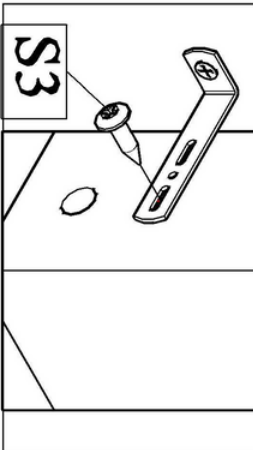

- 1** 
- 2** 
- 3** 
- 4** 
- 5** 

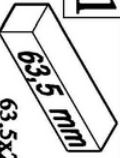
S5	x 64	X1	x 2
	Ø3,5 X 30		63,5 mm 63,5x25x25

